

MOTORDRIVES AUSTRALIA PTY LTD
Ph 0438-060997

VIC
Unit 9, 94 Boundary Rd
Sunshine West 3020

QLD
Unit 5, 12 Nyholt Dr
Yatala 4207

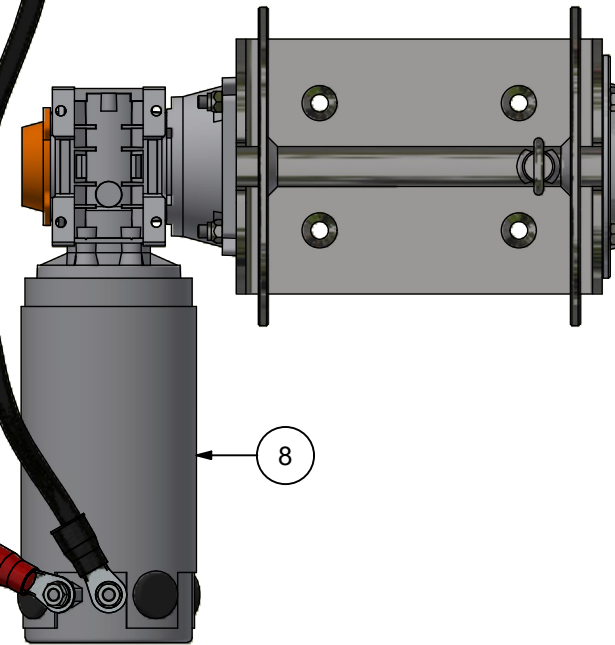
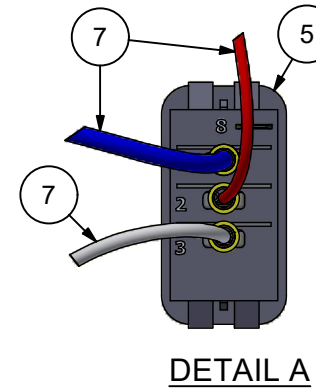

NOTES :-

1. CRIMP TERMINALS SHOWN FOR REFERENCE ONLY. THESE ARE USER SUPPLIED,
2. ALL ELECTRICAL COMPONENTS TO BE MOUNTED AWAY FROM DIRECT WATER SPRAY TO MAINTAIN WARRANTY,
3. SPRAY BATTERY TERMINAL PROTECTANT ON ALL TERMINALS & JOINTS,
4. STUDS ON SOLENOID **MUST POINT UP** (TO THE SKY),
5. TO REVERSE DIRECTION SWAP THE THIN WHITE & BLUE WIRES

PART/MATERIAL LIST	
ITEM	DESCRIPTION
1	B+S CABLE, BLACK, 25 mm2 (LENGTH AS REQUIRED)
2	B+S CABLE, RED, 25 mm2 (LENGTH AS REQUIRED)
3	BATTERY
4	CIRCUIT BREAKER, LEVER TYPE, WEATHERPROOF
5	ROCKER SWITCH
6	SOLENOID, 80 AMP
7	SWITCH WIRE, 3 mm2 (LENGTH AS REQUIRED)
8	TUFF WINCH